

Figure 1

1. Unpack loose parts and remove all packing material from cart.

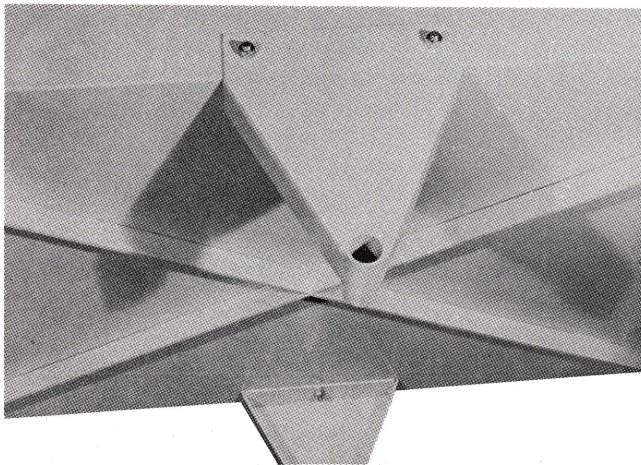

Figure 2

2. Stand body on side or end. Attach axle supports to body using $3/8 - 16 \times 3/4$ inch screws and nuts. Do not tighten securely at this time (Figure 2).
3. Attach the latch bar to the body using the $3/8 - 16 \times 1$ inch screws and nuts. Do not tighten securely. (Figure 3).
4. Insert the axle through the axle supports. On each end of the axle, place drawbar brace, spacer, and washer as shown in Figure 4.
5. Place wheel assembly, valve stem out, on each end of axle. Secure with flatwasher and cotter pin on each end of axle. See Figure 5.

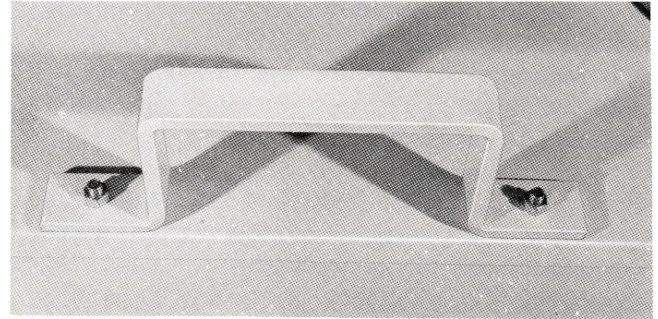

Figure 3

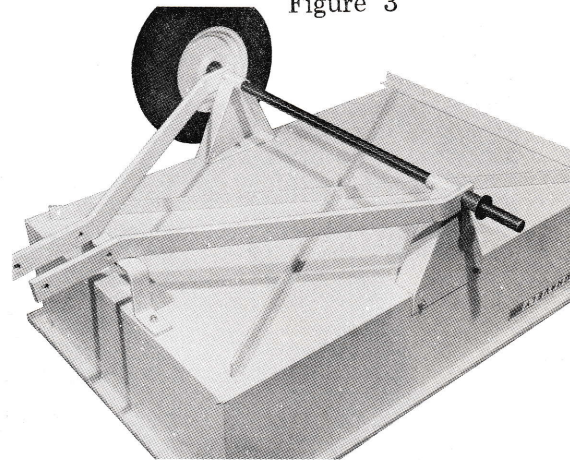

Figure 4

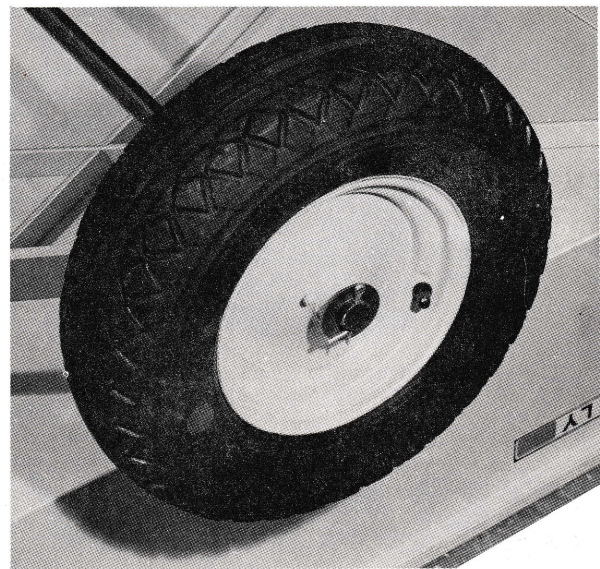

Figure 5

6. Tighten the nuts and screws previously installed.
7. Install the drawbar using the 4½" and 3½" bolts. Install the 3½" bolt through the front hole securing the drawbar braces to the drawbar. Position the handle assembly over the rear hole and secure in place with 4½" bolt. Tighten the front bolt securely. Tighten the rear bolt enough to hold the drawbar in place but allow the handle assembly to pivot. See Figure 6.
8. Place a spring locator, spring and the other spring locator on the 4 inch bolt. Insert the bolt down through the end of the drawbar.
9. Install a nut on the bolt and tighten until there is slight tension on the spring. Thread another nut on the bolt and jam the two nuts together.

When properly adjusted, the spring tension keeps the latch bar against the latch on the handle assembly.
10. Attach the spring from the handle to the drawbar brace as shown in Figure 6.

Grease wheels through fittings liberally with general purpose grease.
11. 15600E1 Cart only - Place the seat in position across the cart body.

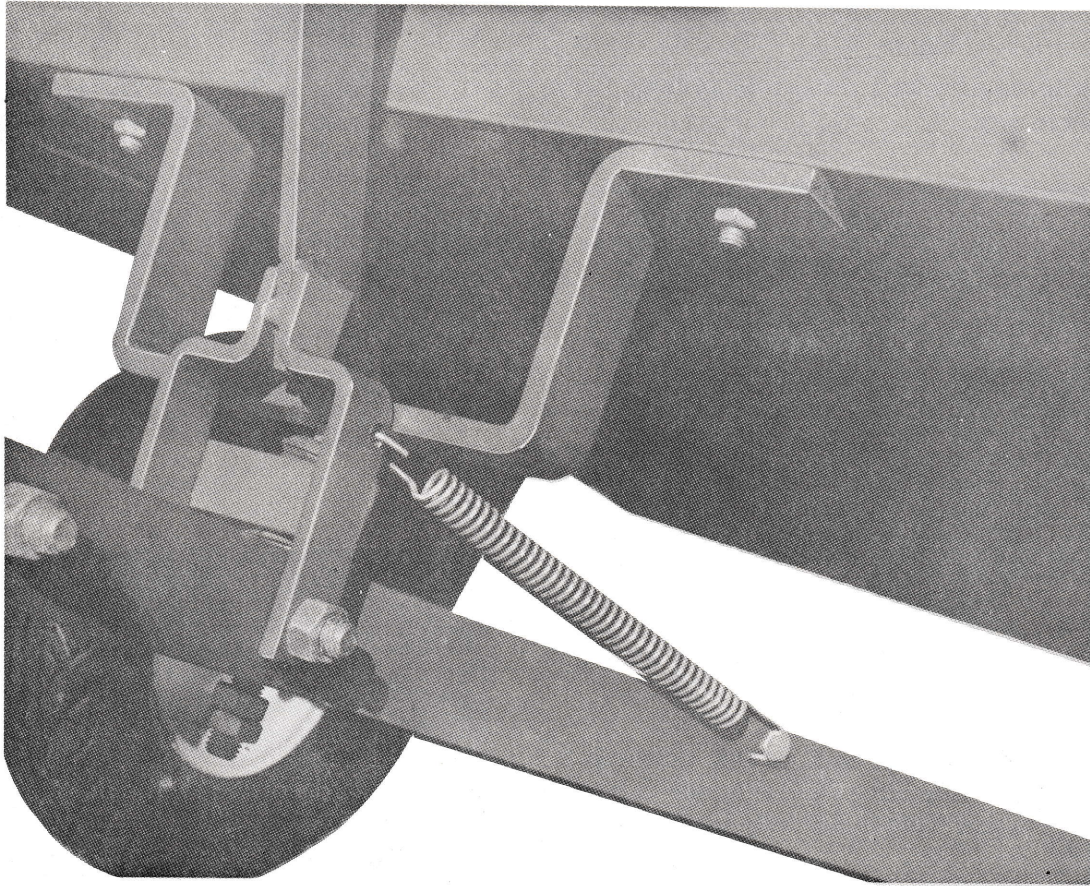

Figure 6

 **GRAVELY**

One Gravely Lane
Clemmons, N. C. 27012